

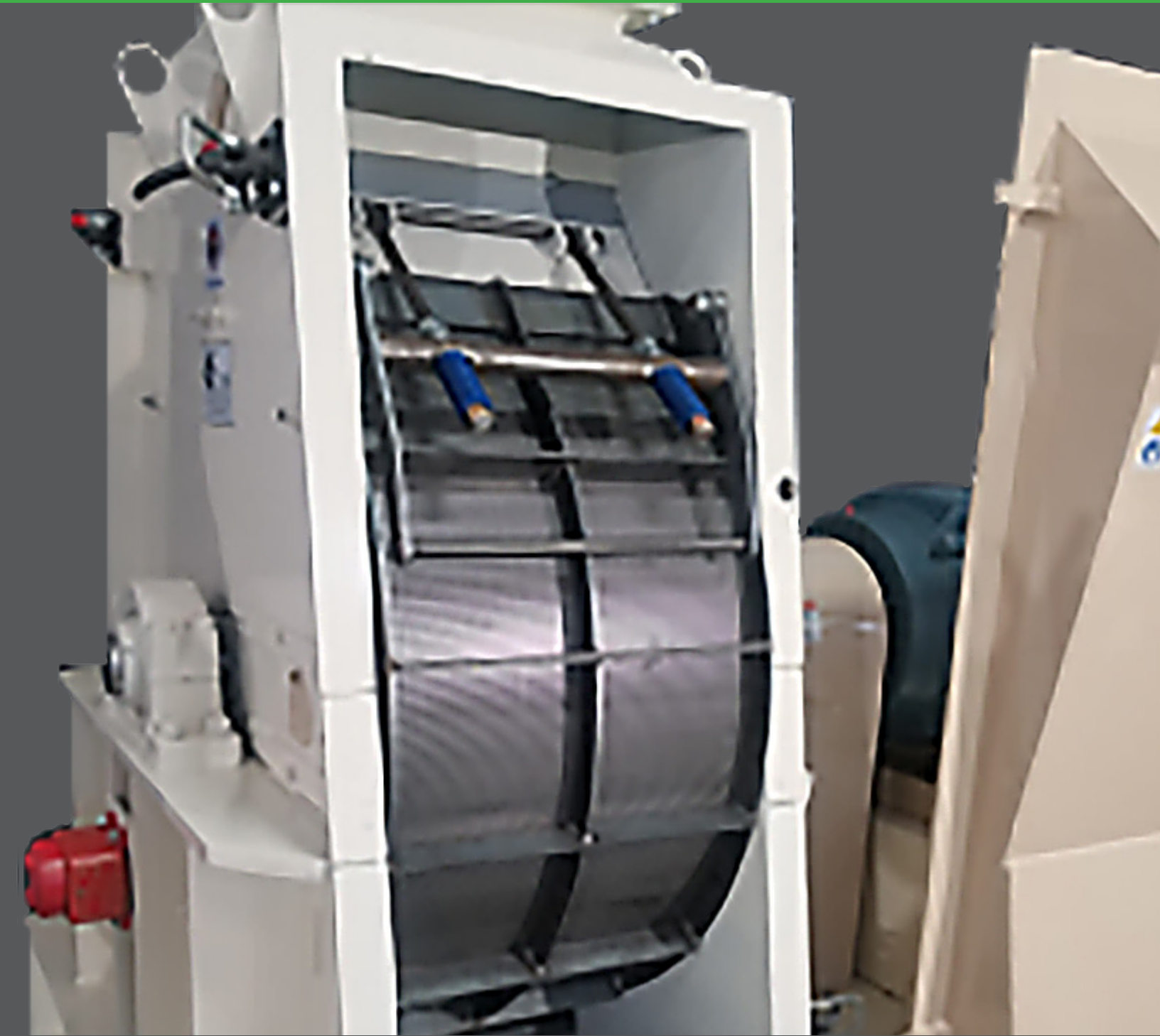

The name you know, experience you trust

Full Circle Screen Hammer mills



(580) 749-4895 | www.csebliss.com
1415 W. Summit Ave Ponca City, Oklahoma 74602

Size reduction equipment comes in a wide variety of shapes and sizes: vertical or horizontal hammer mills, jaw crushers, roller mills and ram-fed grinders, just to name a few. For the most part, the size and shape of the mill/grinder/crusher plays a key role in the functionality of the machine, and for the applications it is best suited for. Nowhere is this truer than with the Full Circle Screen Hammer Mill.

How does a hammer mill work?

- When material enters the grinding chamber, it is repeatedly struck by hammers that flail out as the shaft spins.
- A combination of these hammer blows, particle on particle impact, and impact with the walls of the grinding chamber all work together to break the material down.
- The material remains in the grinding chamber until it is reduced to a size that will pass through the screen.



A peek inside

The full circle screen hammer mill gets its name from the 300 degree screen coverage of the rotor, while all other styles of hammer mills typically have closer to 180 degree coverage of the rotor. The larger the screen area, the greater the opportunity for the material to evacuate the mill.

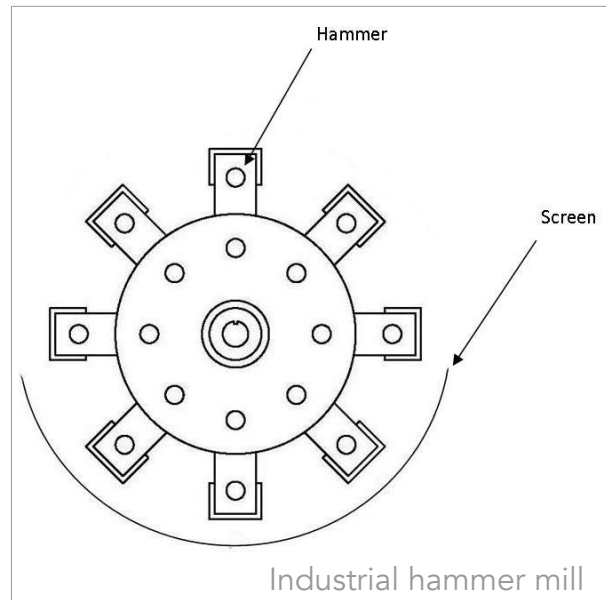
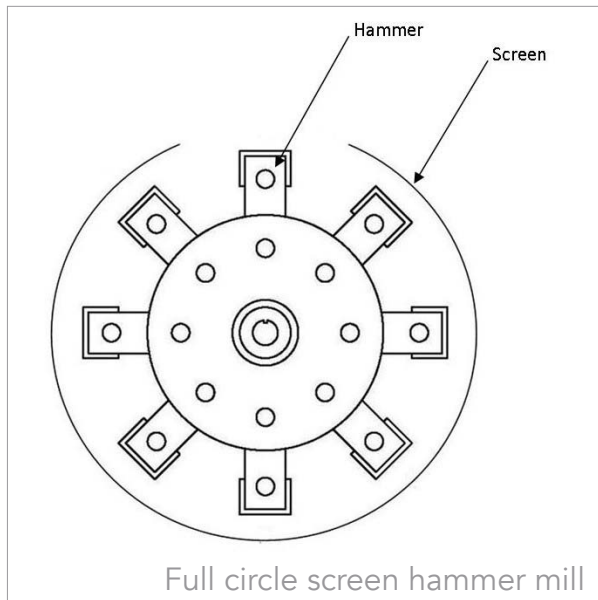

As a result: Full circle screen hammer mills have the highest throughput to horsepower ratio of all hammer mill styles

Ideal applications

To achieve the circular, nearly full coverage of the rotor requires that the screen be somewhat pliable, and therefore relatively thin. In addition, the full circle screen mills use thin, sometimes notched hammers that reduce material with a tearing/grinding action, as opposed to the pulverizing effect of the large, heavy hammers often used in the industrial hammer mills. As a result, the full circle mills are best suited for light, easy to grind materials that do not require initial grinding against a breaker plate.

Ready to Learn More?

Visit our website at www.csebliss.com or reach out directly at sales@csebliss.com



CSE Bliss is a proud member of the Bengal Machine Family of Equipment Manufacturers



(580) 749-4895 | www.csebliss.com